



Paper Type: Original Article

IoT Networks for Autonomous Traffic Management in Smart Cities

Samridhi Sinha^{1,*} , Fatemeh Zahra Montazeri² , Fatemeh Rasoulpour³ 

¹ School of Computer Science Engineering, KIIT University, Bhubaneswar, India; 22051100@kiit.ac.in.

² Department of Industrial Engineering, Lahijan Branch, Islamic Azad University, Lahijan, Iran; montazeri.fatemehzahra@gmail.com.

³ Department of Computer Engineering, Ayandegan University, Tenekabon, Iran; Rasoulpour.72@gmail.com.

Citation:

Received: 10 February 2025

Revised: 19 April 2025

Accepted: 29 May 2025

Sinha, S., Montazeri, F. Z., & Rasoulpour, F. (2025). IoT networks for autonomous traffic management in smart cities. *Supply Chain and Operations Decision Making*, 2(2), 90-97.

Abstract

Autonomous traffic management in smart cities presents a significant challenge due to the growing number of vehicles and the complexity of urban environments. Traditional traffic control systems lack the real-time adaptability to manage dynamic traffic patterns, leading to congestion, accidents, and inefficient energy usage. This research explores the integration of IoT networks to create a decentralized, real-time traffic management system capable of autonomous decision-making. By utilizing Vehicle-to-Infrastructure (V2I) communication, sensors, and edge computing, the proposed system monitors traffic conditions, predicts congestion points, and dynamically adjusts traffic signals and rerouting strategies. A machine learning model analyzes traffic patterns and optimizes flow in real-time, improving overall system efficiency. This research demonstrates that IoT-based traffic management systems offer substantial improvements over traditional methods, setting the foundation for future autonomous traffic control solutions in increasingly connected urban environments.

Keywords: Vehicle-to-infrastructure, Rerouting strategies, Traffic congestion.

1 | Introduction

The rapid expansion of urban populations worldwide has exacerbated city transportation-related challenges, including traffic congestion, elevated emissions, and higher accident rates. Traditional traffic management systems, typically characterized by static control approaches, have proven inadequate in adapting to the dynamic requirements of urban traffic flows. This has led to the development of Intelligent Transportation Management (ITM) systems, which utilize real-time data analysis and adaptive control algorithms to improve traffic efficiency, safety, and environmental sustainability. Enabling ITM integrates advanced technologies

 Corresponding Author: 22051100@kiit.ac.in

 <https://doi.org/10.48313/scodm.v2i2.34>

 Licensee System Analytics. This article is an open access article distributed under the terms and conditions of the Creative Commons Attribution (CC BY) license (<http://creativecommons.org/licenses/by/4.0>).

such as the Internet of Things (IoT) and Vehicular Hoc networks (VANETs), which provide seamless, real-time data connectivity across various elements of urban traffic networks.

The IoT encompasses an extensive network of interconnected devices capable of gathering, processing, and exchanging data in real time. IoT devices are embedded in urban infrastructure, such as roads, traffic lights, and vehicles, within smart city frameworks to facilitate continuous monitoring and responsive management of transportation systems. In traffic management, IoT-based systems utilize data from traffic sensors, GPS devices, and environmental sensors to dynamically adjust signal timings, reroute vehicles, and optimize traffic flow based on real-time conditions [1], [2].



Fig. 1. IoT in traffic management.

2 | Literature Review

2.1 | Intelligent Transportation Management (ITM) with VANETs

Intelligent Transportation Management (ITM) systems extend IoT capabilities by integrating Vehicular Ad-Hoc Networks (VANETs), allowing vehicles to communicate with each other and with nearby infrastructure [3]. VANETs create a decentralized communication system where each vehicle acts as a node in a dynamic, self-organizing network. This capability enables real-time Vehicle-to-Vehicle (V2V) and Vehicle-to-Infrastructure (V2I) communication, which supports various applications such as adaptive cruise control, collision avoidance, and traffic light preemption. VANETs enable vehicles and infrastructure to make cooperative decisions to reduce congestion and accident risks by sharing data on vehicle speed, location, and road conditions. When combined with IoT systems, VANETs become a critical component of ITM, forming an autonomous and highly responsive traffic management ecosystem [4].

Roadside Units (RSUs) are critical components in VANETs; these stationary units are installed along roadways to communicate with vehicles and relay critical data to other RSUs or central systems. By creating an interconnected communication network, RSUs help monitor traffic flow, detect anomalies, and send alerts to improve road safety and traffic efficiency [5].

2.1.1 | VANET-based vehicle communication algorithm using rsu

Step 1. Installed the RSU unit and set the roadside at a specific distance

Step 2. Vehicle connection setup with RSU.

- I. Neighboring vehicle receives a setup connection request from RSU.
- II. Vehicle sends the required data, i.e., location, velocity, and start time, to RSU.

Step 3. Data storage: RSU stores all the received data in a data-based.

Step 4. RSU Interval: if RSU received more than one request from multiple vehicles.

Then, the wait and synchronization method for data storage will be applied per the time interval.

Step 5. call (Image processing in ITM) method is described in the previous section.

Step 6. Vehicle synchronization: If synchronization values are high (because of higher speed vehicle), send the alert data (priority).

Step 7. Eliminate vehicle: remove the low-velocity vehicle and set the lower priority.

Step 8. RSU communication: RSUs communicate with each other and share alert messages to handle congestion.

2.2 | SDN Techniques on VANET

SDN can be characterized as the split between the system (control plane) and the transmitting capacities (data plane). Before data is sent to a network device, the controller creates the rules, and the controllers regulate the logic that dictates how the network behaves. SDN is described as a more modern network that has the potential to overcome the drawbacks of more traditional systems before the older networks were in use for decades [6].

Some researchers are optimistic about the potential of Software-Defined Networking (SDN) to transform automotive network infrastructure. In recent years, SDN has gained recognition as an effective solution for network management. SDN enables communication between the control and data planes through OpenFlow, making it highly adaptable for applications in VANETs.

2.2.1 | Dynamic routing algorithm

A Dynamic Routing Algorithm in the context of VANETs (Vehicular Ad-hoc Networks) uses real-time traffic and network conditions to determine optimal paths for data packets or vehicles. This algorithm continuously adapts routing decisions based on traffic density, vehicle speed, network congestion, and availability of Roadside Units (RSUs) to ensure efficient and low-latency data communication.

Steps of the algorithm:

- I. Initializing parameters.

Define starting and targeting nodes S and T.

- II. Collecting real-time data.
- III. Route discovery.
- IV. Select optimal path.
- V. Route monitoring management.
- VI. Data packet transmission.
- VII. Dynamic re-routing.

Benefits

Adaptability: reacts in real-time to changes in traffic conditions.

Efficiency: reduces delays and minimizes packet loss by avoiding congested routes.

Scalability: suitable for high-mobility VANET environments with numerous vehicles and RSUs.

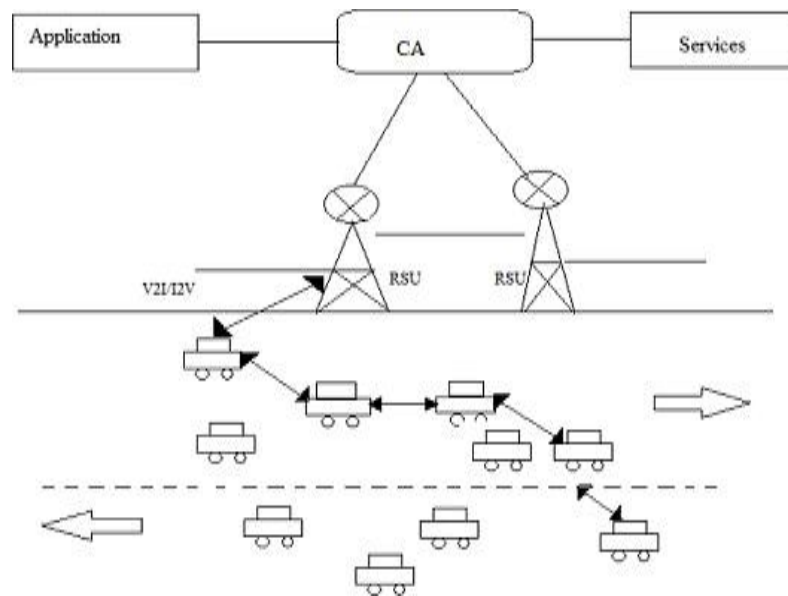

Fig. 2. ITM with VANET.

2.2.2 | Edge-based SDN control

Edge-based SDN controllers play a transformative role in VANET (Vehicular Ad-hoc Network) environments by deploying intelligence closer to roadside units (RSUs) or dedicated roadside servers. This approach moves significant data processing and decision-making from a central location to the network edge, where real-time data is generated and received from vehicles. Deploying these edge-based SDN controllers reduces the dependency on a central controller for every network decision, thus mitigating latency issues arising from long-distance data transmission. This is particularly beneficial for applications requiring immediate action, such as emergency alerts and collision avoidance, where every millisecond counts.

In VANETs, edge-based controllers enable local decision-making directly at the edge, empowering the network to respond quickly to real-time events without the delays associated with sending data to a central location. For instance, when traffic congestion or an accident occurs, the nearby edge-based SDN controller can promptly process data from vehicles and RSUs, analyze the situation, and provide rapid alerts to other vehicles in the area. This immediate processing capability greatly enhances the network's responsiveness, supporting critical applications such as V2I and V2V communication. As a result, drivers and autonomous systems receive timely updates about potential hazards, allowing for preventative actions that improve safety and traffic flow.

One of the primary benefits of edge-based SDN in VANETs is the reduction of latency. By minimizing the reliance on a central controller for processing every decision, edge-based SDN allows for localized and efficient network management, enhancing the performance of real-time applications. This setup also improves the system's scalability; the network can handle more data without compromising performance by distributing processing tasks across multiple edge controllers. The approach also ensures better network resiliency, as localized processing at the edge makes it less susceptible to single points of failure that can affect centrally managed networks.

However, edge-based SDN deployment in VANETs does come with its challenges. One significant issue is maintaining consistency across the network, particularly when edge controllers operate independently. Coordination with the central SDN controller is essential to avoid inconsistencies in decision-making across

the network, as local decisions made at different edge points might conflict with one another. Additionally, independent operation of edge controllers could lead to network partitioning, where different network sections become isolated due to a lack of synchronization. This requires sophisticated protocols to maintain seamless communication and coordination across all controllers, ensuring that the network operates cohesively even as decision-making is decentralized to the edge.

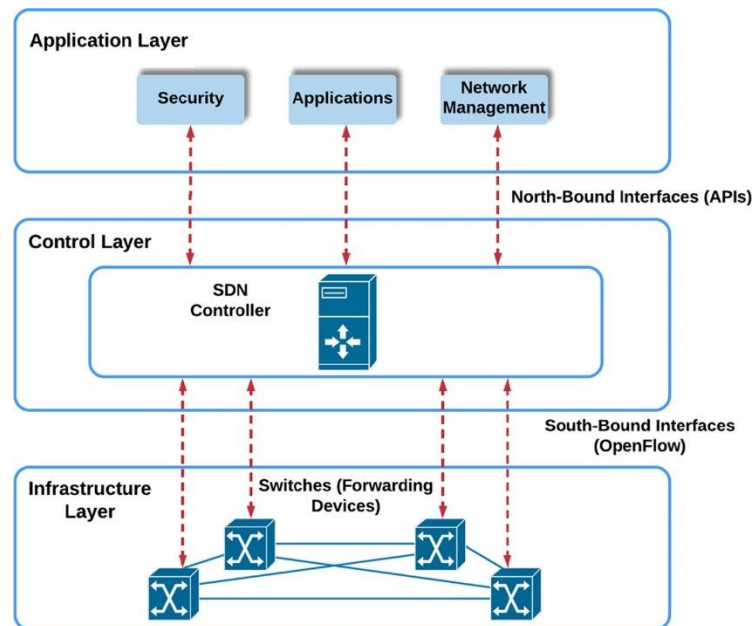

Fig. 3. Layered architecture of SDN [7].

3 | Benefits of IoT-Based Traffic System

Real-time traffic monitoring and data collection

IoT and VANETs enable continuous data collection from multiple sources, including vehicle sensors, Roadside Units (RSUs), cameras, and environmental sensors. This real-time data provides a comprehensive view of traffic conditions, enabling faster and more effective responses to changes.

Benefits: real-time monitoring allows traffic management systems to detect congestion points, monitor vehicle speeds, and identify accidents immediately, which helps minimize delays and improve overall traffic flow.

Adaptive traffic signal control

IoT and VANET technologies enable adaptive traffic signal control, where signal timings can adjust dynamically based on real-time traffic data.

Benefits: this reduces congestion and minimizes wait times at intersections. For example, traffic lights can prioritize high-density areas or emergency vehicles, improving overall efficiency and reducing commuter travel time.

Enhanced road safety and collision avoidance

VANETs enable vehicles to communicate with each other V2V and with infrastructure V2I, which supports advanced safety features like collision avoidance and emergency braking.

Benefits: with instant data exchange between vehicles, VANET-enabled systems can alert drivers to potential collisions, sudden stops, or other hazards. This reduces the likelihood of accidents and enhances road safety for all users.

Efficient route optimization and navigation

By utilizing IoT data on current traffic conditions, congestion, and road closures, navigation systems can dynamically adjust routes for optimal travel times.

Benefits: route optimization prevents drivers from entering high-traffic areas, reducing congestion and saving fuel. This also improves commute predictability and reduces driver frustration.

Reduction of traffic congestion and emissions

IoT and VANET can help distribute traffic more evenly across available routes by redirecting vehicles based on real-time data, which reduces bottlenecks in high-traffic zones.

Benefits: efficient routing and reduced congestion lower vehicle idling time, which reduces fuel consumption and emissions, contributing to better air quality and a cleaner urban environment.

Enhanced emergency response

VANET allows emergency vehicles to communicate with traffic signals, RSUs, and other vehicles to clear their paths.

Benefits: emergency vehicles can reach their destinations faster, significantly improving response times during critical situations. This capability can be lifesaving in medical emergencies and accidents.

Reduced cost of traffic management

Automated traffic monitoring, adaptive signal control, and dynamic routing minimize the need for manual traffic management interventions [8].

Benefits: This lowers operational costs for municipalities, as fewer personnel are needed for on-the-ground traffic control, and maintenance costs can be reduced by early detection of infrastructure issues.

4 | Challenges and Limitations of IoT-Based Smart Traffic System

Although IoT-based smart traffic systems present significant potential through machine learning and data-driven approaches, several disadvantages and limitations exist in their implementation. Firstly, infrastructure challenges—such as road zoning, urban planning, and construction-related issues—pose major obstacles to deploying this technology. Additionally, high-speed, internet-enabled data transmission is crucial to realizing the full capabilities of IoT-based traffic systems, meaning that any network unavailability or instability could disrupt the entire traffic control operation [9]. This makes effective data management a complex task within such systems.

Secondly, the large number of devices accessing the central network increases the risks of hacking and system malfunctions. To ensure a secure and resilient smart traffic application, a robust security layer is essential to protect against cyber threats. Personal data utilized in traffic management must be safeguarded, with strict measures to prevent unauthorized access [9]. Therefore, secure data handling is paramount when implementing these advanced applications. Moreover, the system faces challenges with abstract social concepts, such as norms and values, which are difficult to accommodate in IoT-based traffic management.

Furthermore, as this system is primarily data-driven, its decision-making relies on information processing. In certain unpredictable situations, the system may encounter unexpected outcomes, a scenario less common in traditional traffic management [10].

5 | Conclusion

The integration of IoT (Internet of Things) and VANET (Vehicular Ad-Hoc Networks) technologies into Intelligent Transportation Management (ITM) systems represents a groundbreaking advancement in addressing the complex challenges of urban traffic management. As urban populations and vehicle densities increase, traditional traffic management systems struggle to maintain efficiency, safety, and environmental

sustainability. IoT and VANET offer a dynamic, real-time approach that significantly improves these legacy systems by harnessing vast networks of connected devices and decentralized communication channels. This research highlights how IoT and VANET collectively transform traffic management by enabling adaptive responses, improving safety, optimizing routes, and offering extensive data for long-term planning.

The real-time data collection and monitoring capabilities enabled by IoT sensors and VANET's V2V (vehicle-to-vehicle) and V2I communication create a network capable of responding instantaneously to changing traffic conditions. This data enables adaptive traffic signal control, which reduces wait times at intersections and dynamically prioritizes emergency vehicles or high-traffic areas. This reduces congestion, smoother traffic flow, and reduces environmental impacts through lowered emissions. With enhanced safety features like collision warnings and cooperative driving facilitated by VANET, road safety is significantly improved, minimizing accidents and safeguarding lives.

The research also acknowledges several challenges associated with the widespread implementation of IoT- and VANET-enabled ITM systems, including reliable, high-speed communication networks, robust cybersecurity measures, and scalable infrastructure to accommodate growing urban demands. Data privacy and protection remain primary concerns as traffic management systems collect large volumes of sensitive vehicle and driver data. Furthermore, integrating heterogeneous IoT devices and achieving interoperability across different networks is essential for seamless operation but remains technically challenging. Addressing these limitations will be necessary for unlocking the full potential of IoT and VANET in traffic management.

Beyond immediate benefits, IoT and VANET in ITM systems provide valuable insights for urban planners and policymakers by offering detailed traffic pattern data that can shape future infrastructure projects. The data collected can inform decisions on road expansions, public transit development, and safety enhancements, allowing cities to adapt proactively to changing transportation needs. Such data-driven planning is integral to developing sustainable, resilient smart cities that efficiently handle increasing transportation demands.

In conclusion, IoT and VANET represent the future of traffic management, offering efficient, adaptable, and safety-enhancing solutions. While scalability, security, and interoperability challenges remain, ongoing research and technological advancements are steadily addressing these issues. By investing in IoT- and VANET-based traffic management, cities worldwide can lay the groundwork for intelligent transportation systems that promote a seamless, safe, and sustainable urban environment. As such, these technologies are not just innovations but essential elements in building the smart cities of tomorrow.

Acknowledgments

I would like to extend my sincere gratitude to Professor Dr. Hitesh Mahapatra from Computer Science & Engineering Department, KIIT University, for their invaluable guidance, insight, and encouragement throughout the development of this research.

Funding

This research received no external funding.

Data Availability

The data used and analyzed during the current study are available from the corresponding author upon reasonable request.

Conflicts of Interest

The authors declare no conflicts of interest regarding the publication of this paper.

References

- [1] Mohapatra, H., Rath, A. K., & Panda, N. (2022). IoT infrastructure for the accident avoidance: An approach of smart transportation. *International journal of information technology*, 14(2), 761–768. <https://doi.org/10.1007/s41870-022-00872-6>
- [2] Baisakh, Mohapatra, H., & Guru, A. (2025). Behavioral insights into compression: A study of Move-to-Front-or-Middle deterministic online algorithm through sequence classification and characterization. *International journal of information technology*, 17(1), 189–203. <https://doi.org/10.1007/s41870-024-02218-w>
- [3] Lilhore, U. K., Imoize, A. L., Li, C. T., Simaiya, S., Pani, S. K., Goyal, N., ... & Lee, C. C. (2022). Design and implementation of an ML and IoT based adaptive traffic-management system for smart cities. *Sensors*, 22(8), 2908. <https://doi.org/10.3390/s22082908>
- [4] Baras, S., Saeed, I., Tabaza, H. A., & Elhadef, M. (2018). VANETs-based intelligent transportation systems: An overview. *Advances in computer science and ubiquitous computing: csa-cute 17*, 265–273. https://doi.org/10.1007/978-981-10-7605-3_44
- [5] Ouhmidou, H., Nabou, A., Ikidid, A., Bouassaba, W., Ouzzif, M., & El Kiram, M. A. (2023). Traffic control, congestion management and smart parking through vanet, ml, and iot: A review. *2023 10th international conference on wireless networks and mobile communications (WINCOM)* (pp. 1-6). IEEE. <https://doi.org/10.1109/WINCOM59760.2023.10322908>
- [6] Hamza, S. J., & Hassan, S. I. (2024). Adaptive of software defined network (SDN) technique to improve the connectivity between two vehicles in vehicular AD HOC network (VANET). *ITM web of conferences* (Vol. 64, p. 01005). EDP Sciences. <https://doi.org/10.1051/itmconf/20246401005>
- [7] Sultana, R., Grover, J., & Tripathi, M. (2021). Security of SDN-based vehicular ad hoc networks: State-of-the-art and challenges. *Vehicular communications*, 27, 100284. <https://doi.org/10.1016/j.vehcom.2020.100284>
- [8] Lanke, N., & Koul, S. (2013). Smart traffic management system. *International journal of computer applications*, 75(7), 19–22. https://www.academia.edu/download/61550731/Smart_Traffic_Management_System20191218-126240-m8c3tp.pdf
- [9] Rabby, M. K. M., Islam, M. M., & Imon, S. M. (2019). A review of IoT application in a smart traffic management system. *2019 5th international conference on advances in electrical engineering (ICAEE)* (pp. 280-285). IEEE. <https://doi.org/10.1109/ICAEE48663.2019.8975582>
- [10] Bousdekis, A., Lepenioti, K., Apostolou, D., & Mentzas, G. (2021). A review of data-driven decision-making methods for industry 4.0 maintenance applications. *Electronics*, 10(7), 828. <https://doi.org/10.3390/electronics10070828>